

*System Design*

# **“Prabhat- Alternative Education”**

Background research & opportunities

---

Submitted By: Parag Sarma,  
Toy & Game Design,  
4th Sem, PGDPD, NID,  
2011

Guide: Gayatri Menon

# Contents

1. Background research
2. Parag's opportunities



# Prabhat

## Background Research

### Prabhat

The central mission of the Foundation is to create learning opportunities through a new school which will welcome children who cannot cope with exam-oriented school systems. To achieve this, Prabhat believes it important for its team to be engaged with a selection of teaching and service activities that can help build a competent team of teachers who have the experience and flexibility to adapt to a variety of learning needs.

First step has been to open a small 'learning through activity' centre, Prabhat for Kids. A Jeevan Taleem programme has been started to serve special children with life skills they need, and to help understand the special education requirements which should be made available through a new school designed to serve their needs. Workshops and camp opportunities for special children have also helped Prabhat to interact with their needs and with their parents. Other partnerships are assisting Prabhat to build its awareness and experience in education. Children at the Prabhat Centres in Maninagar and Satellite learn life skills that can move them toward confident and productive adulthood, at home and in the world.

They are also trying :

- Medical Awareness
- Educational Awareness between people
- Education for every children(including special needs)
- Job opportunities(special quota) for special needs.
- Awareness about Govt. policies for special needs.



## Support & Funding:

Prabhat has a limited of funding systems. They do not have some basic fund support from government till yet. Only some donations from people and sometimes from some schools like Riverside School who provide them furniture and some equipments. Tata will want to help them in CBR programs. They have a little fees of 500 hundreds which is not enough.

Some retired and knowledgeable volunteers help for Prabhat's CBR programe.Special educators(maninagar)also work for a minimum payment. Sometime some doctors and physiotherapist come to the center for help Prabhat.

# Members of Prabhat:

## Students

Students in Prabhat have mental problems, Most of them need special care from their environment, and many of students can live 'normal life'

## Teachers

Teachers are trained in special education area. They are specialized to take care of children, Problems are low-loan and too much students.

## Family members

Families of Prabhat's children have various range of background. Many of them are coming from rural area of Ahmedabad. They loves their child but not many understanding of the conditions and special teaching method.

## Partner organizations

There are some of partner organizations. Most of connections are from Mr,Keshav Chatterjee.

## Friends & neighborhood

Most of children in Prabhat doesn't have a friends and has no contact with their neighborhoods. It seems because of a lack of understanding or experiences of mental disorder.

# Education contents:

Formal and Non Formal Education has basic differences. Formal education is classroom-based, accompanied by trained teachers. Informal education happens outside the classroom, in after-school programs, community-based organizations. Both formal and informal education settings offer different strengths to educational outreach project, while both schools and after-school programs serve students.

Real learning can happen in a setting where kids feel less intimidated or more comfortable than they do in a formal classroom.

'Prabhat' education system's are also not formal education. Their education system help to come out a special needs children become a simple like a normal. Children. Their teacher never followed them to normal school syllabus,only gives them how to survive on society,Prabhat helps these special children for basic needs not school based education .

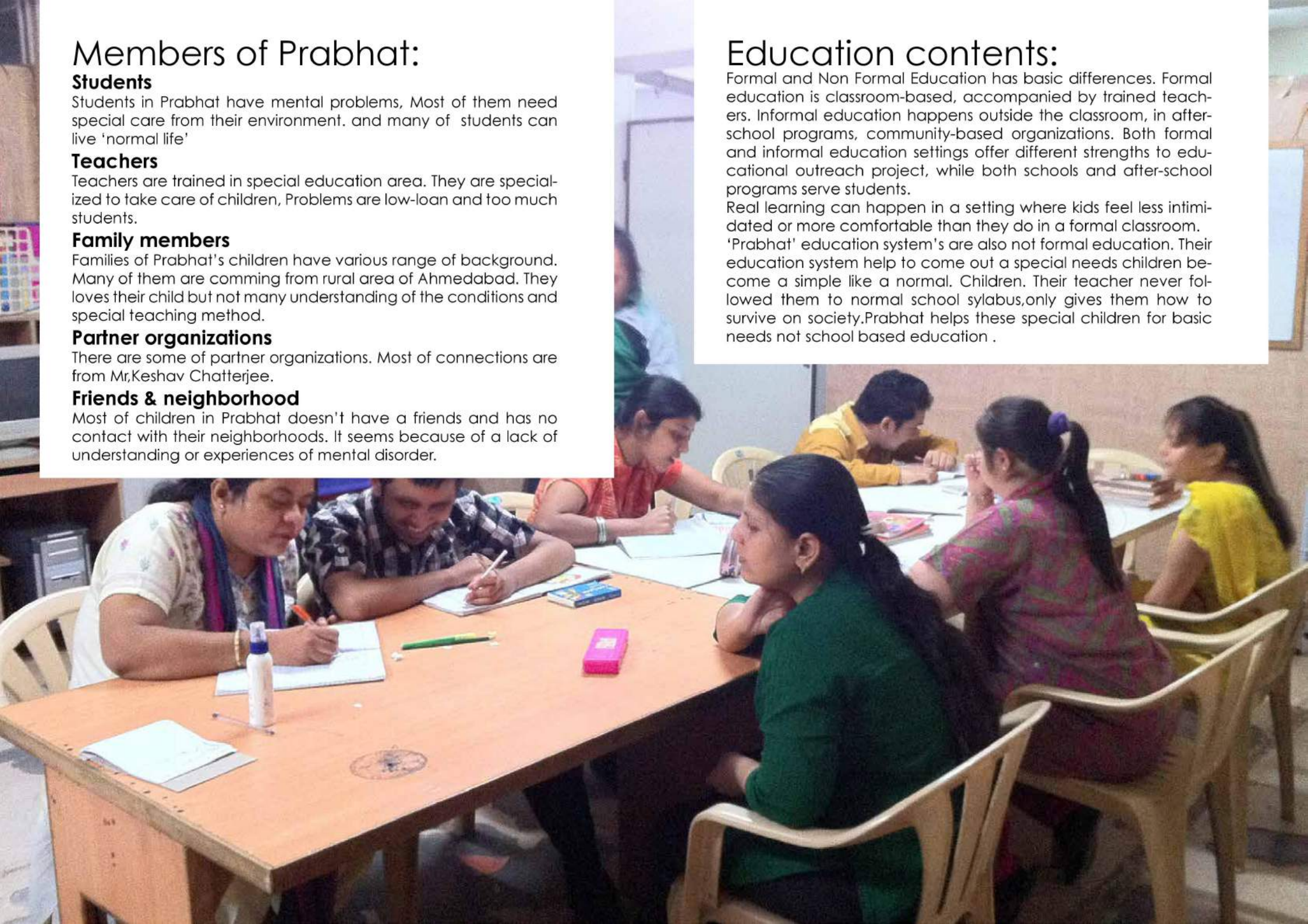



## Outdoor Activities:

### **Picnic**

This program is a part of C.B.R (Community-Based Rehabilitation Programme). Once a month, every family members of Prabhat go to picnic. They play together with other mently disorder children. It seems good to be together, but need more facinate playing programs to attract other family members.

### **Visit to Riverside school**

This program is belong to the Riverside school's Design for Giving competition program, Children from Prabhat go to Riverside school and have relationship with them. and also the students from Riverside schools are comming to the Prabhat once a month.

### **Special olympics**

This program improves childrens physical abilities, and also let them join a community activities, which triggers them to re-join the society.

### **Party**

This program make children enjoying within a community.



## Case studies 1. **Aashka**



### **12 years.**

She come to Prabhat from last 1.5 years before. Her mom also joined as a teacher of this centre from last six months before. She has Autistic problem and she expression her emotion by gestures only. She moves her head anytime and never speak with anyone sometime except her mother. She likes to nail polish and not like to wear any kinds of jewelry. She likes to traveling by auto and never doing friendship with anyone. She is very bared in communication problems and socialization also. In play, she likes only swings and loves her grandmother to much.

## Case studies 2. *Harshit*

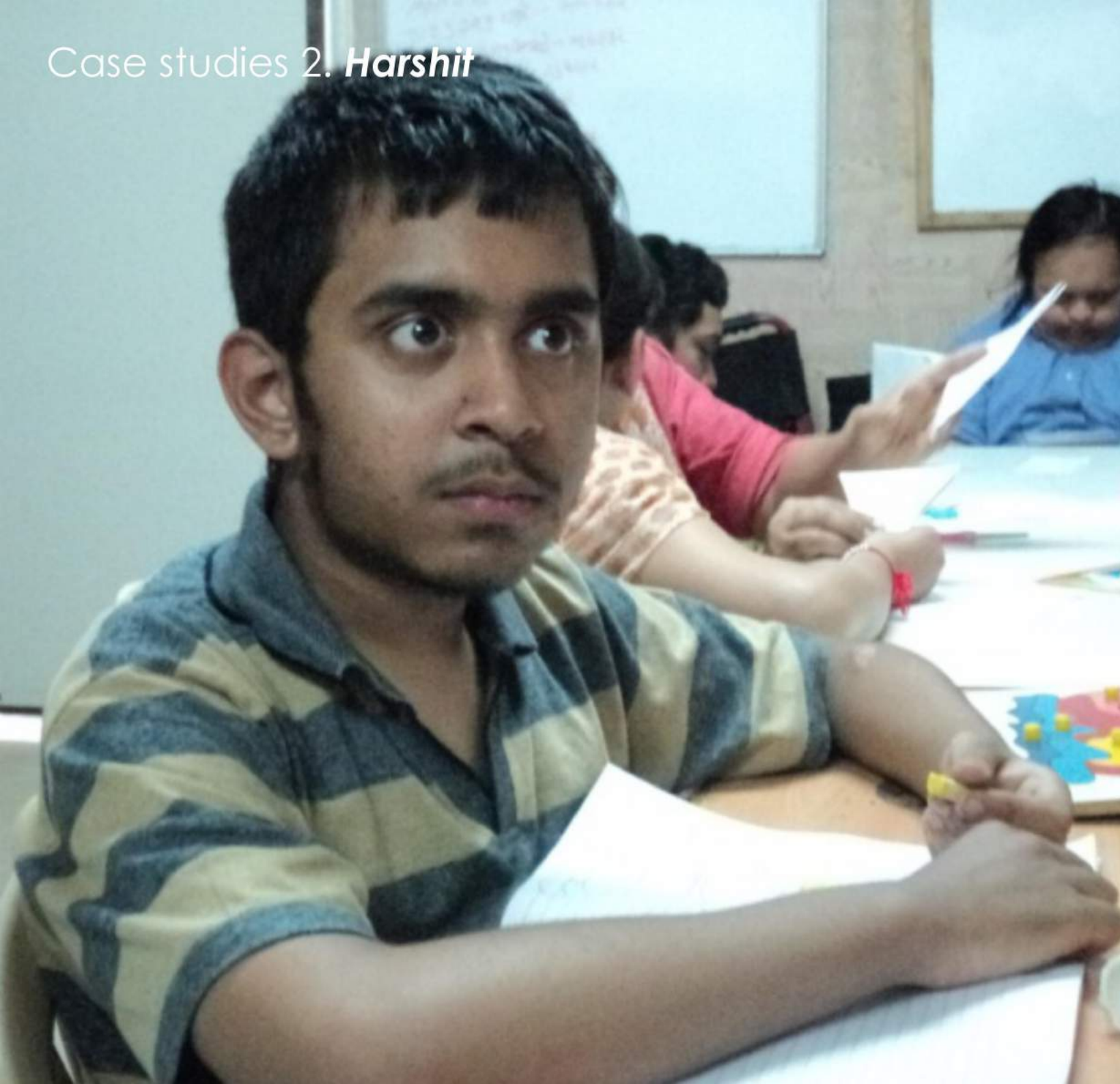

### **13 years.**

He joined Prabhat from last six months before. He is Autistic, Hyperactive, speaking very limits and if someone reply him by his name ,he does not give any reply. He wants to live alone and like to help his mom in kitchen. His behavior is self intimate .He is good in coloring and drawing .He does not like to be a socialize, he does not want to share his thing with another person.



## Case studies 3. *Anjali*



### **11 years.**

She is almost normal condition, but she is moderate M.R. Her mother realize that Anjali is not normal when she was 6months. She has some friends near her home area. She likes to watch T.V shows, She can read but not write. She oftenly help her mother's house works, and her mother hopes that Anjali become a good house wife.

## Case studies 4. *Kangana*



### **18 years.**

Joined at Prabhat in 2007

Kangana's condition is severe M.R. and also behavior problem. Activities of daily limit(ADLT) is not easy to her. She has problem with grasping, so kangana needs help from other when she has meal. She doesn't like to hear high & heavy sound.

# TWO Perspectives

## Prabhat

Children with mental disorder need special care in special facility.  
It may make children harder to go back to the society.

## Act 1995.

Children with mental disorder should learn with normal children.  
Children will feel many difficulties while they are in school.

Perspectives

TWO



Opportunities  
Parag Sarma

# Highlights from the research

- Need of education among special children
- Spaces of living seems under-estimated
- Promotion of Prabhat brand
- Giving presence to awareness programs for such community.

## Purpose:

To provide better educational options for the children in Prabhat.



# Context

Social morality about Mental disease/Minority

Anand Niketan, Satellite

-Lent a classroom in basement

Unnati

-Similar organization like prabhat  
-Helping in teaching programs

Strength/Weakness

S: C.B.R

Connections with riverside school  
Connected to B.M. institute/unnati

W: Funding system(not enough to develop)

Not enough volunteers to work

Small building

Teachers are not stay for long term(not enough payments)

Not proper advertising

No government support

Rural/Urban area(slum)

-Poor family

-Not properly educated

-No awareness of social condition

Funding

-Donations

-School fees 500Rs./M

B.M.Institute of Mental health

-Teaching program for special needs

-Educate teachers for prabhat

-Active helper

Priorities

Empower funding system

Alternative education system

Connection to society(C.B.R)

Needs

Prabhat

-More students(more than 100students)

-More funding/bigger space

-More connections

Students

-Good/better education system

-Care their disease

-Happy today, better future

Teachers

-More payments for Prabhat

-Modern teaching facilities

Parents

-Child become a normal

-Child to be an independent

-Child can help their family

Society

-Take care of Special childrens

-Educate them to be normal

-Keep the social morality

Social Perception

-Creating Social awareness

(Medical, job opportunities, education, society.etc)

Doctors/Physiotherapist

-Therapy for C.P.

-2days/week, 3hours

Education methods

-Special care/education

-Teaching basic skills

-Block building system

-Therapy for special needs

-C.B.R Program

-Learnign by doing

Riverside school

-Student exchange program

-Design for giving competition

-Students have subject to help mentaly disorder children

-Lent equipments(Bus, furniture)

Structure

Director of Prabhat

# Prabhat

Maninagar

-77 students

-5 special educators

-5 volunteers (C.B.R)

-3 class rooms

-2 therapy rooms

-Based on slum families

Satellite

-16 students

-5 teachers(mothers)

-3 volunteers

-1 huge classroom

-I.E.P(individual education program)

-From rich family background

Toys for mental disease

Materials, forms, colours

Students

-Mentaly disorder

-Mainly 7-18years old

-M.R, Downsyndroms, ADHD, C.P, Aitism

Marketing & Promoting

Parallel Organization in Ahmedabad

-Shradha(Austic to Artistic)

-Antarnad foundation

-Apang Ekta Samity

-Blue Rose Day care center

Craft sector

-Wooden furniture works of Chandkheda,Lackquer used (Ahmedabad)

The Persons with Disabilities Act, 1995 (Equal Opportunities, Protection of Rights and Full Participation) Act, 1995.

Working in these field:

a) Blindness

b) Low vision

c) Leprosy cured

d) Hearing impairment

e) Loco motor disability

f) Mental Retardation

g) Mental illness Persons with Disability

Advertising

-Newspaper, T.V, Illustrations, Web base. etc

Small scale local industry

-Wooden industry

-Turning wooden work

Facilities:

1.Education : Every child with disability shall have the right to free education till the age of 18 years with free books, uniforms and scholarships/appropriate transportation and barrier-free environment.

2.Employment : 3% vacancies in Government shall be reserved for blindness/low vision, hearing impairment, loco motor disability and cerebral palsy.

3.Non-discrimination : All the places of public utilities public buildings, rail compartments, buses, ship and aircraft shall be made barrier-free to give easy access.

4.Affirmative Action : Aids and appliances shall be made available. Allotment of land shall be made at concessional rates for housing, business, special schools, etc.

5.Mass awareness : Mass Awareness through TV/radio and other media.

Government support:

8th December: National Day For Mentally Retardation.

National I institute For The Mentally Handicapped(NIMH), union government

autonomous body which is working under the Ministry Of Social Justices Empowerments.

NIMH works field :

1.Human Resources development.

2.Research & Development.

3.Development of Models of Care and Rehabilitation.

4.Documantation and Dissemination.

5.Consultancy services to voluntary organization.

6.Community based Rehabilitation.

7.Extension and Outreach programmes.

# Purpose

# Analysis

## -Questioning

-New system/scenerio  
(Promote service-system)

-Strength/weaknes s

-Short term/  
Long term benifits

## -Prioritise

-Implications

-Needs

## -Feasibility

## -Product

-Who will make it  
-How much will it cost

-Time → -Environment

-Use

-The implication,  
the manufacturer,sale,  
retail,technical,mechanical,material trends

-Raw materials → -Investment → -Packaging  
-Process → -Distribution → -Delivery

-Production → -Use → -After use

- ex) Toy → -How to play → -Whole life cycle

# Context

Cultural condition  
Culture resauces

Location

Funding

Stake holder

# Observation

Social perception

Parallel organization systems

New material

Process

Production

Work Structure

## Organization

Organization Structure

User

Subject area

Consumer

Market

Products competition

Trend

Environment safty

## Purpose



# Opportunity:1

To support of CBR program (community based rehabilitation)

## Why:

Prbhat has some CBR (community base rehabilitation) program which includes 4 different slum area like Shah-E-Alaam, Daali Limbda, Nawab kahan ni chali, Chandora Lake etc. Prabhat has a little volunteer who are working in these area and still it is not famous and they have a big loophole in this part. For this program which actually an important part of their mission, needs more money and promotion CBR program also.



Existing hand puppets





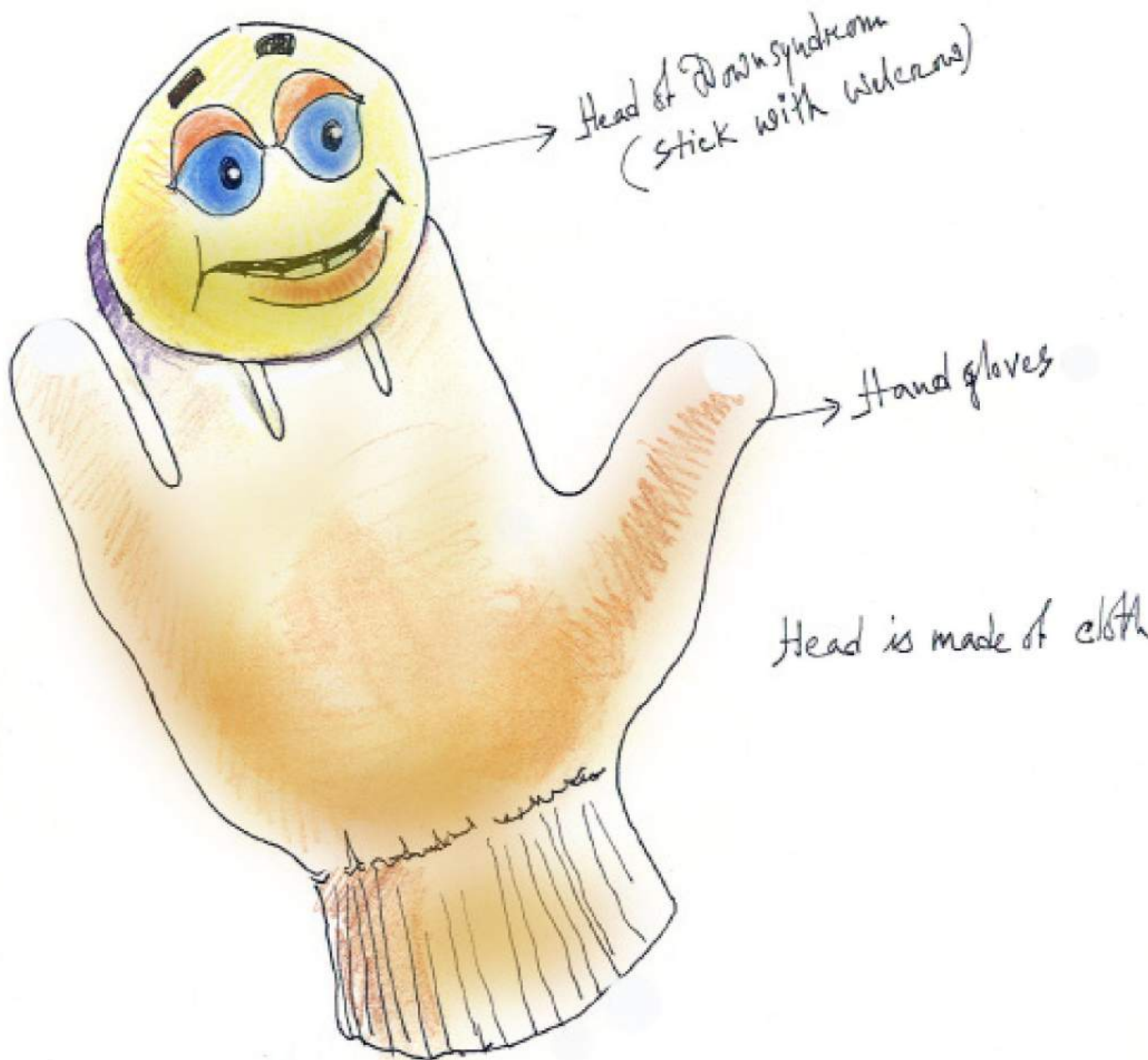

*Hand Puppets*

## How:

(a)Prabhat sometime organizing huge rehabilitation program at that slum area. But it is only based on simple discussion about dieses and about more rehabilitation. For better promotion of this program, some awareness activity through puppet show, which will be designed to teach non-disabled children and even the public about various disabilities, and to show them that being disabled never stopped anyone from being a good classmate, a good friend and shouldn't keep a person from leading a satisfying life. Through this program people can know that even though the persons who are disabled are different, they can lead full and satisfying lives and instead of being ignored, they are potential playmates and even friends.

## Feasibility:

All characters for the story are hand puppet where player can change puppet's head and body part. All puppets are making from soft material like stuffing toys. Puppets are produce through a workshop, where giving training to teacher of Prabhat for puppet making and teacher will start a mission for children for puppet making. It will help children also in future when they will go back to his/her society after education, start also individual business of puppet making and also help to his/her family for earning money.

## Uniqueness:

Awareness program through puppets are not very existing. People also like to see this kind of show where they get some fun and easily understand also. These kinds of puppets(part assemble)are not common and the case of rehabilitation area, it is quite new.

## Production:

All puppets are made from scrape cloth and wastage cotton(for stuffing),collecting material from local tailors by paying hundred rupees and get a lots of cloth for puppets.



(b) Another way, string puppet(kath-putli)also help for supporting Prabhat's CBR program. These string puppets will make by local puppet makers(kath-putliwala).

The production cost of string puppets are to low and this medium is to famous for public also and a big communication system between puppets and public. This kind of puppets has not need to much material also.So,this string puppets are also one of the way of express Prabhat's story on CBR program.  
Materials: Soft wood,westage cotton,fabric,threads for dancing puppets by hand.



Existing wooden toys

## Opportunity:2

To design Toys for Prabhat promoting

### Why:

To promoting Prabhat with branding approach which will help to market of some toy ranges which is given them an unique approach for selling and marketing it.

### How:

Toy range are making from small wooden scrape with the assist of small scale wooden industry and products sell in market, it also help to Prabhat for their name branding and also use these toys for as a educational kit which help for their children and also supply for not only another similar organizations but also among normal children. For marketing their product, Pehchaan also help.



# Toys for promoting Prabhat

## Feasibility:

All product ranges are made from scrape wood and manufacturing by local wooden vendors which not need huge amount of money, because the wooden scrape are collected from local furniture industry as a wastage and for buying scrape, they have used only a little amount of money which they get back after their product selling, and one person from Prabhat who will involve for taking care of making product. Over all concept is based on "Earning money for Prabhat without investing large amount of money."



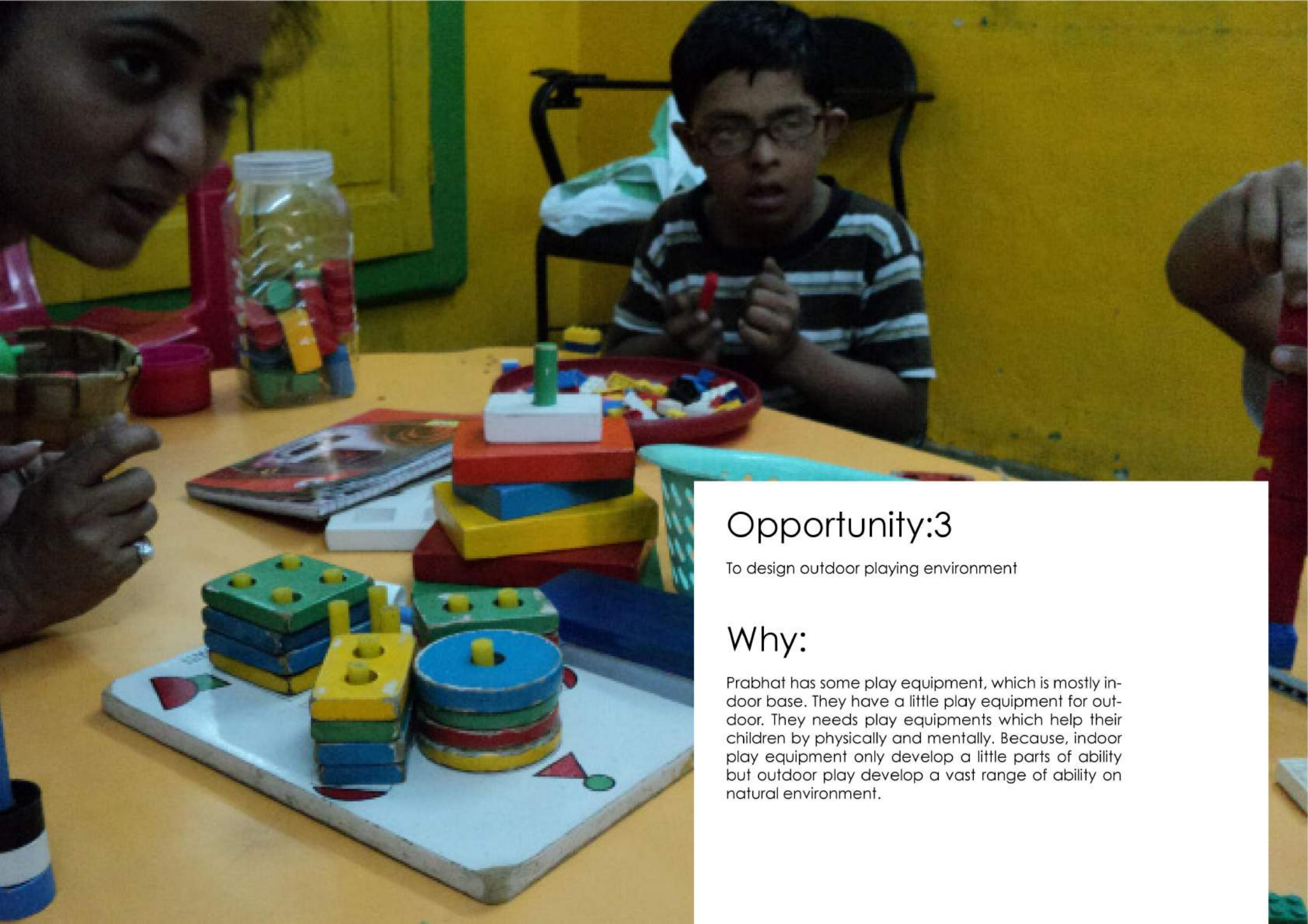

## Opportunity:3

To design outdoor playing environment

### Why:

Prabhat has some play equipment, which is mostly indoor based. They have a little play equipment for outdoor. They need play equipments which help their children by physically and mentally. Because, indoor play equipment only develop a little parts of ability but outdoor play develop a vast range of ability on natural environment.

## How:

Prabhat(Maninagar)branch has a small place in front of their institute which will convert to an interactive play ground where their children can play and interact with the installed equipment and Prabhat (Satellites)student also come to play here which still not connecting accept some occasional program. Riverside school children also sometime comes to Prabhat (Maninagar),they also can play in this ground and these equipment can be moveable also.

### Existing playing equipments for outdoor

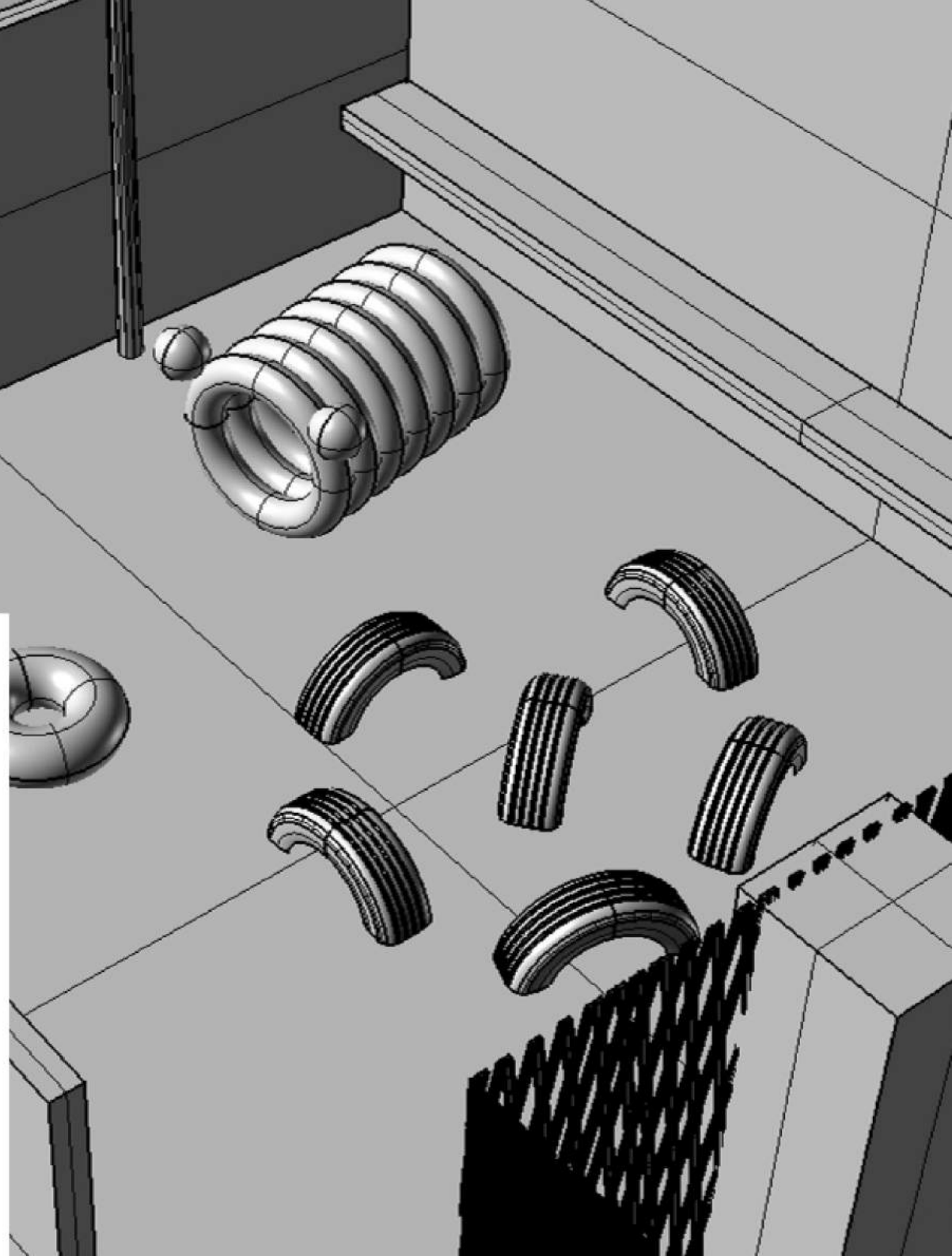

## Feasibility:

All equipments of this playground are made from second hand rubber tube, tire and also considering child safety and the point of view from low manufacturing cost. Because, Prabhat can buy all rubber tubes and tire from car garage and can pint it. These playing equipment will help Prabhat children for playing, jumping on tube etc and the tire can be used as a music chair kind of activity which enrolled their children around this play ground and also Riverfront student also associate with Prabhat children for playing activity. This ground is folding like if Prabhat want to shift al playing equipment(outdoor),it can easily possible.





## Opportunity:4

Role play

### Why:

(a)Role play will encourage children for imagination, imitations, and performance abilities and also for basic skill improvement which much needs for Prabhat.







Interactive story book

## How:

(a) Want to make an interactive picture book, which will develop the children's imagination, imitations and basic skill also.

Through this story book he/she would be one of the parts of the story and role himself like the depiction of the stories and it also gives them fun and develop these children's imagination capacity. As a character of story, he/she would be develop finger movements ability. In first page story of three cats who are drinking milk from the pot. Through this image children also act like cat. Same next page has another story (e.g. two dancer is dancing) and also react like the story.

## Feasibility:

This interactive story book help to develop children visual communication skill along with basic finger and hand movement skill when they react like the story image.

Riverside school student also come to Prabhat, they also might be the part of this activity. Even in home also special children can play with his/her sibling also. The illustrations of that book will also make by student. The character for roleplaying will make from wastage cloth which will be collects from tailor and stitching. These character of the stories will be put along with the book.

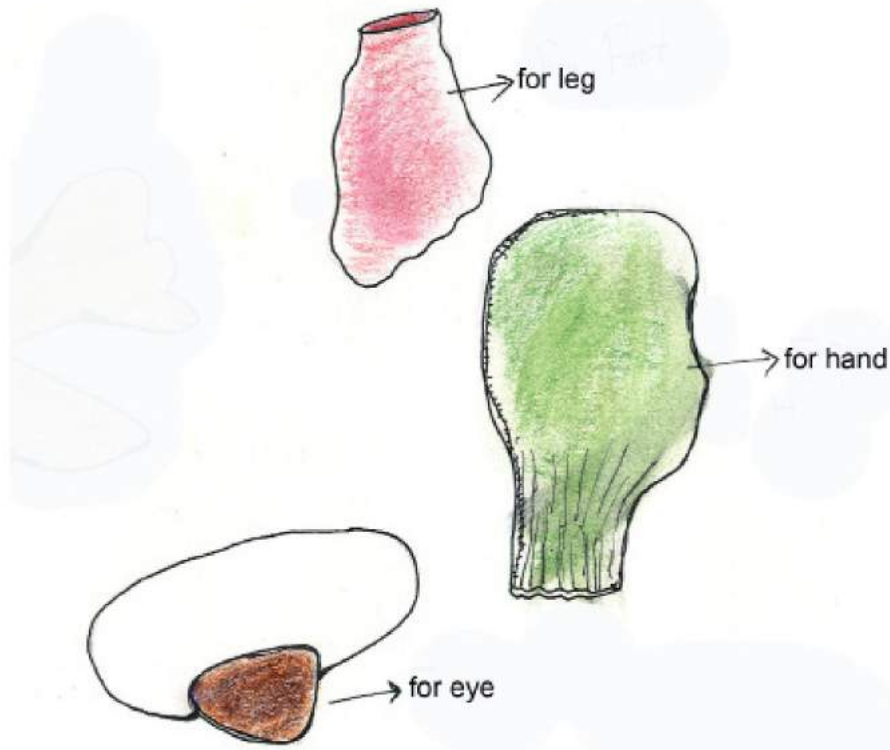

(b) To Design "disability as an ability" kit-

Want to develop a range of product which will help to encourage for role play act.

## How:

Riverside school children comes to Prabhat for play with children. Prabhat has different kinds of children which has different kinds of ability. Riverfront school children will play with Prabhat children. eg. If one children does not able to do anything by left hand, then Riverfront school student also wearing this product on his/her left hand which will pack his/her hand and doing some act, which that disable children tell him.

These range of product will make from scrape cloth and it will encourage for friendship and also for acting ability which will help to improve Prabhat children's basic skill like hand movement, body movement and through these activity.



## How:

(c) These role play corner which will contain some caps or turbans, it will also be involved in development for children's motor skills (how to wear on head by hand) and also develop about an idea on different people's headgear which also improve their vision about different places and people and also give them a funny and competitive atmosphere.

Material: For this concept, needs only some cloth turban.

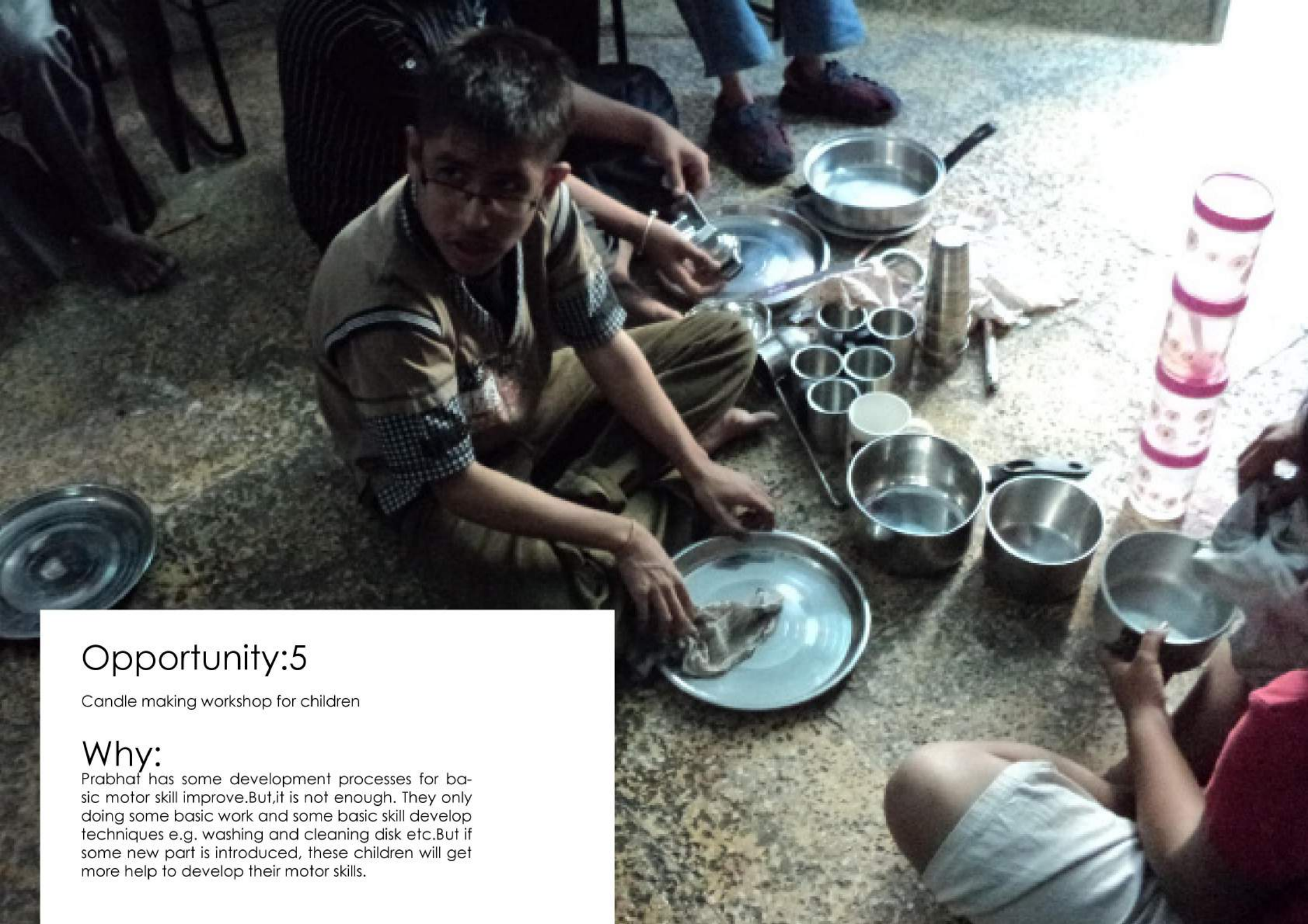

## Opportunity:5

Candle making workshop for children

### Why:

Prabhat has some development processes for basic motor skill improve. But, it is not enough. They only doing some basic work and some basic skill develop techniques e.g. washing and cleaning disk etc. But if some new part is introduced, these children will get more help to develop their motor skills.



Existing kit for motor skill developments in market

## How:

Want to start a workshop for children, where children will do some clay work which is plasticine and they make some form which depicts some image like an airplane, ship, bird, etc. (will tell them whatever you like to make). They have also their own imaginary world, which they make in clay. This activity will help their creative activity and also help basic hand skill development.

After their work, it is converted to a mold and pouring it with wax by children where the Prabhat teacher helps them as a course curriculum.

## Feasibility:

For starting this program, Prabhat needs a little money and they can sell it through Pehchaan who already involves to sell Prabhat's existing craft products and they can sell these candles as a product which is made by some extraordinary people with extraordinary work. Pehchaan also has their own website, from where they can advertise these products.

Through this mission, people also start to know about Prabhat.

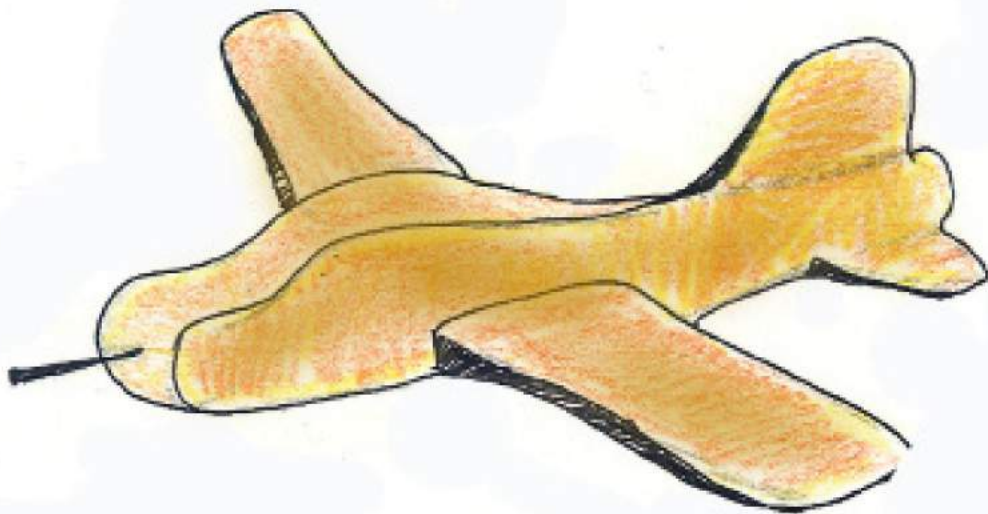

candle



# Final Products

# Final Product

Story based puppet show proposed for assist C.B.R program.

## FINAL SYSTEM WORKING PROTOTYPE:

After all of my opportunities, I given the final proposal of puppets (katth-puttli which are belongs from local puppet art made by puppeteers. The main interesting part of these puppet's are, they are totally traditional which are existing in Ahmedabad and very popular among the common people. This final opportunity has a lots of potentiality and also strongly feasible for "COMMUNITY BASED REHABILITY" program. Puppets are known as best communication medium of general public from old ages.

## FINAL STORY:

There are a poor family. This family has four members KARIM who is a 15 years boy, he has not right leg. But he lives very joyfully. His elder brother's name is MUSTAAK..he is a 23 years school boy, but he does not do anything for their family. SALMAANBHAI is KARIM's father and SAYERA is his mother's name. They are poor family, but although they are poor, they lives very polite and gently in DAALI LIMBDA area of Ahmedabad. KARIM's mother father loves his elder brother MUSTAAK very much then him. But KARIM lives very enjoy fully. One day, some Govt. Officer came to their village to find a good boy who is physically disable but who have potential for doing everything with joyfully. Govt people has an offers to disable people to sent them for special Olympics.

KARIM is selected for special Olympics by govt officer and KARIM gets medal in special Olympics. These day govt has offers to their family, 5000 RS/mnth as a honors for winners the game. Thus, KARIM bring a great name for his family and also for his area, his state and country also. Govt offers him a USA trip with his family.

Actualy, this story is inspired from a real story of a disable children of "PRABHAT" who wins the award in special olympics. They are not "DISSABLE" but can say specially able. This stories characters are developed from the local people of the slum area where "PRABHAT" is still running CBR program.

## PRODUCTION COST OF THE PUPPETS:

The manufacturing cost of the puppets are not very much. Each character's manufacturing cost is only 85 RS, which are the local puppeteer's selling price.

### PROCESS OF MAKING:

The same process of manufacturing of local puppets. Material are mainly softwood like GULMOHAR,stuffing cotton(all are wastage),normal enamel based paint and fabric.

### THE PUPPET SHOW:

Puppets will show by puppeteers group whose coast are not very much.1400 RS for one show.







Thank You...